

VERTICAL BEND DOWN - ELEVATION

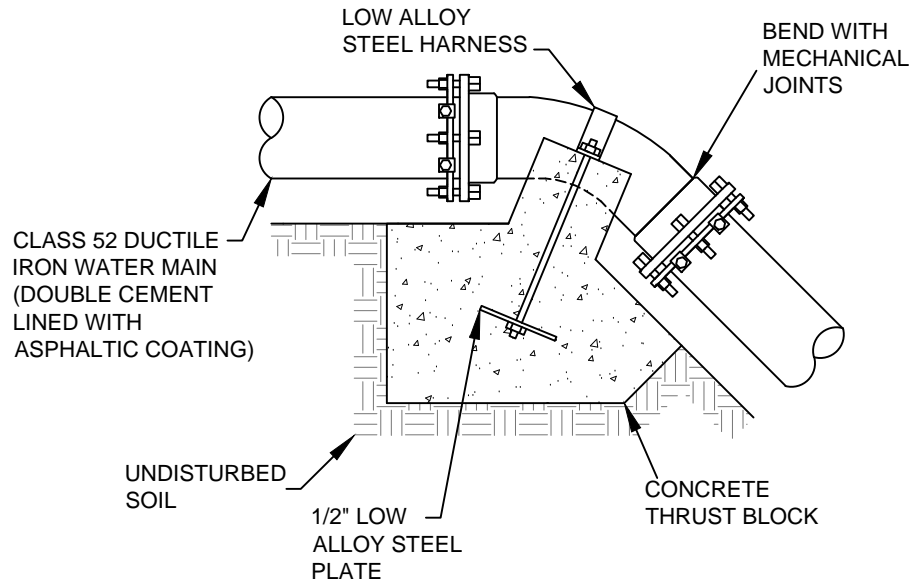

NOTES:

1. USE PENNDOT CLASS A CONCRETE.
2. CONCRETE MUST BEAR UPON UNDISTURBED SOIL.
3. ROUGH FORMS SHALL BE USED TO CONTAIN CONCRETE FOR THRUST BLOCKS. MECHANICAL JOINTS ARE NOT TO BE COVERED.
4. ALLOW POURED CONCRETE THRUST BLOCKS TO SET PRIOR TO BACKFILLING.
5. ALL PIPE AND FITTINGS TO BE WRAPPED IN POLYETHYLENE ENCASEMENT.
6. ALL FITTINGS ARE TO BE MECHANICALLY RESTRAINED.
7. ALL BOLTS, NUTS, AND WASHERS EXPOSED TO DIRECT BURY CONDITIONS SHALL BE LOW ALLOY STEEL. AFTER ASSEMBLY ALL BOLTS, NUTS, AND WASHERS SHALL BE COATED WITH COAL TAR (BITUMASTIC 50 AS MANUFACTURED BY CARBOLINE OR APPROVED EQUAL).
8. RESTRAINED M.J. RETAINER GLANDS (MEGALUG OR EQUAL TO) MAY BE SUBSTITUTED FOR THRUST BLOCKS WITH EWW ENGINEERING APPROVAL.
9. LOCK TYPE GASKETS (U.S. PIPE FIELD LOCK GASKETS OR APPROVED EQUAL) ARE TO BE USED FOR 40' TO EITHER SIDE OF FITTINGS.
10. ANY MODIFICATION MUST BE APPROVED BY THE EWW ENGINEERING DEPARTMENT IN ADVANCE.

VERTICAL BEND DOWN - SECTION

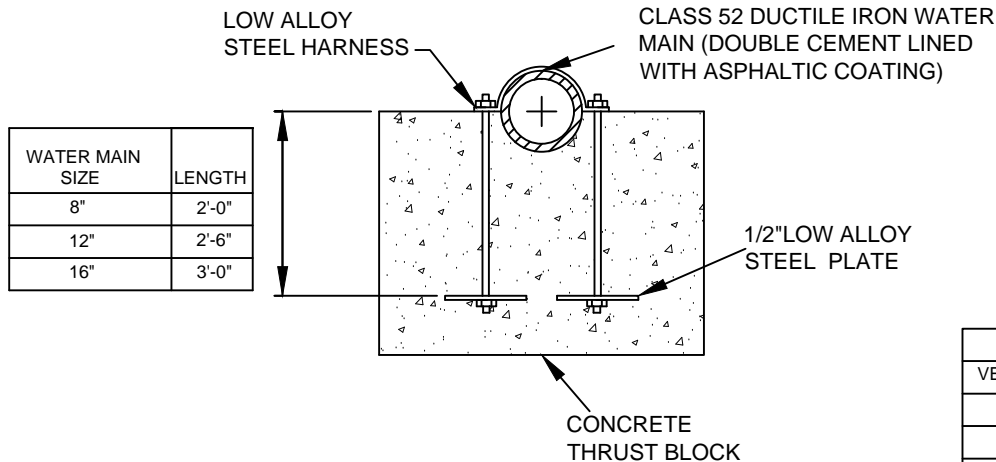

MINIMUM THRUST BLOCK SIZES

FITTINGS		3" OR 4"	6"	8"	10"	12"	16"
VERTICAL BENDS DOWN							
1/4 (90)°	SF	8.0	8.0	12.0	16.0	25.0	36.0
1/8 (45)°	SF	4.0	4.0	6.0	8.0	12.0	16.0
1/16-1/32 (22 1/2 - 11 1/4)°	SF	4.0	4.0	6.0	8.0	12.0	16.0

DRAWN BY: PH
DATE: OCT 2010

APPROVED BY: CP
NOT TO SCALE

CONCRETE THRUST BLOCKING (3 OF 3)

ERIE WATER WORKS
240 West 12th Street
Erie, PA 16501

