

NOTES:

1. ALL GATE VALVES 12" DIAMETER AND SMALLER, SHALL BE RESILIENT WEDGE, MECHANICAL JOINT (MJ X MJ) WITH ACCESSORIES, AND SHALL CONFORM TO THE SPECIFICATIONS SET FORTH IN THE ANSI / AWWA C515 STANDARD OF THE LATEST REVISION AND CERTIFIED TO ANSI / NSF 61. VALVES SHALL HAVE A WORKING PRESSURE RATING OF 250 PSI. CONSULT THE EWW ENGINEERING DEPARTMENT FOR VALVES LARGER THAN 12" IN DIAMETER.
2. VALVES BODY AND BONNET SHALL BE DUCTILE IRON.
3. VALVE SHALL OPEN TO THE RIGHT (CLOCKWISE), WITH A 2" OPERATING NUT.
4. VALVE SHALL HAVE A NON-RISING STEM. THE STEM AND WEDGE NUT SHALL BE HIGH-STRENGTH BRONZE.
5. THE WEDGE SHALL BE DUCTILE IRON OR CAST IRON AND FULLY ENCAPSULATED IN MOLDED RUBBER. THE WEDGE SHALL BE SYMMETRICAL AND SEAL EQUALLY WELL WITH FLOW IN EITHER DIRECTION.
6. VALVES SHALL HAVE A SEALED LUBRICATION RESERVOIR FOR EASE OF OPERATION AND EXTENDED OPERATION LIFE. STEM SHALL BE SEALED BY THREE O-RINGS. THE TOP TWO O-RINGS SHALL BE REPLACEABLE WITH THE VALVE FULLY OPEN AND WHILE SUBJECT TO FULL RATED WORKING PRESSURE.
7. THE VALVE SHALL HAVE THRUST WASHERS LOCATED WITH (1) ABOVE AND (1) BELOW THE THRUST COLLAR TO ASSURE TROUBLE-FREE OPERATION OF THE VALVE.
8. ALL GASKETS SHALL BE PRESSURE ENERGIZED O-RING TYPE SEALS. NO FLAT GASKETS SHALL BE USED.
9. VALVES SHALL BE FUSION-BONDED-EPOXY COATED CONFORMING TO AWWA C-550 LATEST REVISION.
10. THE VALVE SHALL HAVE A SMOOTH UNOBSTRUCTED FULL SIZE WATERWAY, FREE OF POCKETS, CAVITIES AND DEPRESSIONS. BI-DIRECTIONAL FLOW SHALL NOT IMPEDE COMPLETE SEAL AT FULL RATED PRESSURE.
11. ALL ACCESSORIES (FASTENERS: NUTS, BOLTS, WASHER, ECT.) USED TO ASSEMBLE THE VALVE BODY, BONNET, AND OPERATING NUT SHALL BE STAINLESS STEEL AND COATED WITH COAL TAR (BITUMASTIC 50 AS MANUFACTURED BY CARBOLINE OR APPROVED EQUAL).
12. ANY MODIFICATION MUST BE APPROVED BY THE EWW ENGINEERING DEPARTMENT IN ADVANCE.

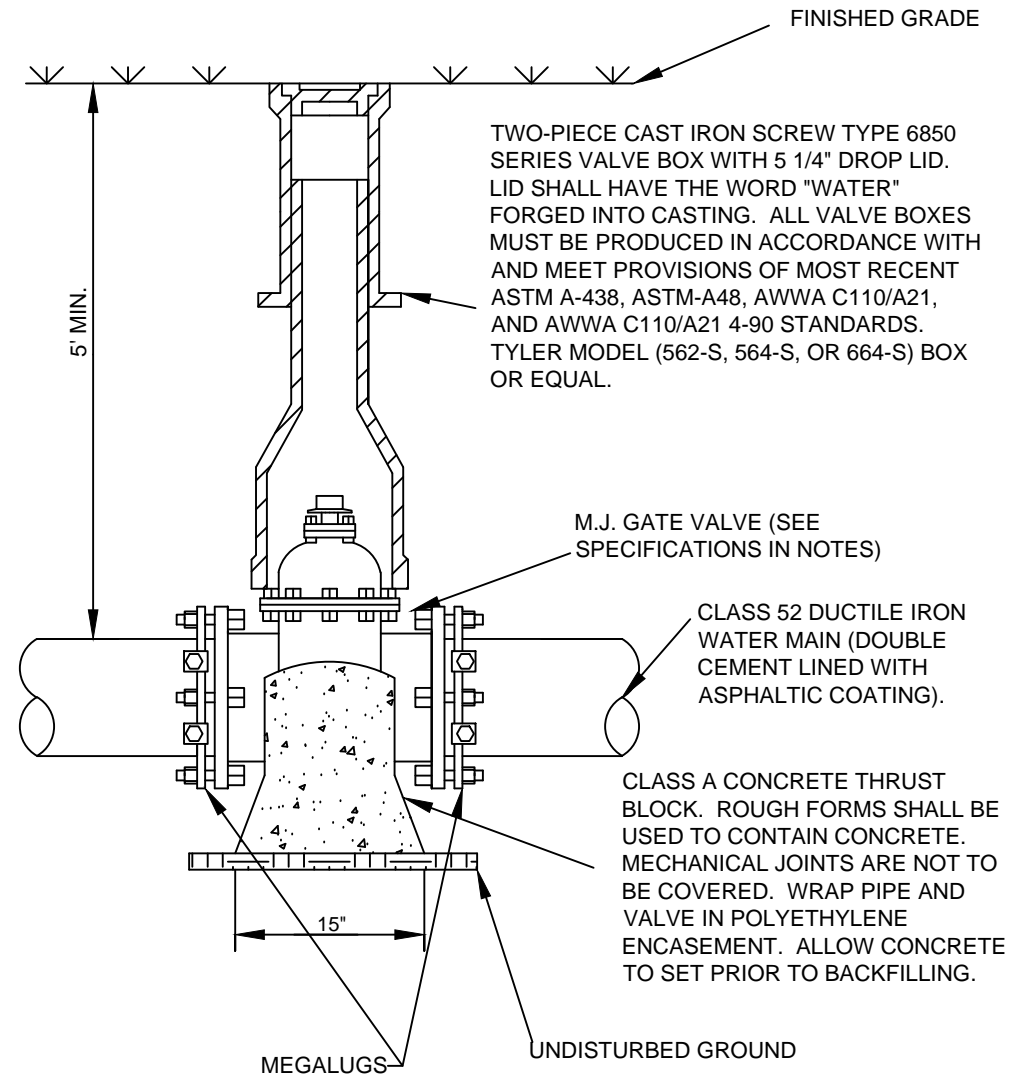

## MAINLINE GATE VALVE AND VALVE BOX

|                |                 |
|----------------|-----------------|
| DRAWN BY: PH   | APPROVED BY: CP |
| DATE: OCT 2010 | NOT TO SCALE    |

ERIE WATER WORKS  
240 West 12th Street  
Erie, PA 16501

